

WRIGHT 

+JOHN 14:6

Since 1966

MATTHEW 6:33

**DYNAMIC**<sup>®</sup>

Cornerstone of Quality

CORE TOOLS  
IN HAND FOR  
**RAILROAD**  
DEMAND.



FORGING RESPECT



FORGING WRENCHES.

FORGING RATCHETS.

FORGING SOCKETS.

FORGING ATTACHMENTS.

FORGING RESPECT®.



# FOR ALMOST 100 YEARS WE'VE BEEN INNOVATING, ENGINEERING, AND FORGING TOOLS THAT EXCEED WHERE OTHERS FAIL.

At Wright, our vision has always been to ensure confidence and protect those that are building our tomorrow. And when we do that, we're forging more than just tools. We're forging partnerships. We're forging respect. Something we don't intend to lose anytime soon.

# AMERICAN MADE QUALITY.

Since 1927, the Wright Tool Company has manufactured the highest quality hand tools in the industry. No exceptions. Upon striking the first forging here in Ohio, our tools have been engineered and crafted by hardworking Americans, for hardworking Americans. We have no intentions on slowing down either—Wright has continued to innovate when everyone else says "good enough"—and we have the patents to prove it. All of these are reasons why our tools aren't inexpensive, because frankly, you get what you pay for. We forge tools for those who understand value isn't represented by a price tag, but rather downtime and replacement.

Professionals working in the world's harshest environments demand performance and safety that exceeds the standard, because failure is not an option. This is why we only use the best—Wright alloy steel. The use of our proprietary steel, precision heat treating, and advanced manufacturing techniques results in products of long life, durability and toughness. The end result are products built to exceed industry standards, because good enough is never good enough.

We finish that American innovation and hard work off with an equally hardworking lifetime warranty—one that you'll likely never need.



## WE CONFIDENTLY BACK OUR TOOLS WITH A LIFETIME WARRANTY

Therefore for as long as you own it, any product manufactured by Wright Tool which fails to render service due to defect in workmanship or materials will be replaced at no charge.

Wright Tool does not provide any warranty for products labeled other than Wright Tool or Cougar Pro. This limited lifetime warranty replacement does not apply to any defects caused in whole or in part by improper use, accident, abuse, alteration, and neglect or normal wear from use. Wright Tool makes no other warranties, express or implied, with respect to the tools or their suitability for specific applications. Wright Tool neither assumes, nor authorizes any person to assume, any other warranty or obligation express or implied. Please contact your Wright distributor for additional information on our warranty policy and process for replacement. You can also call 800.321.2902 to speak with Wright Customer Service.

## TOUGH TOOLS MADE FOR TOUGH WORK

Commercial Construction

Government GSA

Heavy Equipment &  
Machinery

Industrial MRO

Infrastructure

Mining

Oil & Gas

Power Generation

Solar Energy

Wind Energy

WHEN YOU'VE BEEN FORGING FOR THIS  
LONG, YOU LEARN A LOT. THE MOST  
IMPORTANT? DON'T PUT YOUR NAME  
ON SOMETHING THAT ISN'T THE BEST.

WRIGHT

# THE LAST PRIVATELY HELD, ALL-AMERICAN- MADE TOOL MANUFACTURER IN THE US MARKET.

Wright provides industrial-grade, premium-quality wrenches, ratchets, sockets and attachments to the professional users who make their living using their tools in the industrial, contractor and MRD markets. All of Wright tools are sold through independent distribution along with some key national accounts, but these days we are looking to speak less to the distributor and more to the end user. When the end-user starts demanding Wright quality, the distributors will be happy to provide it. All Wright manufactured products are made in the U.S.A. and carry lifetime guarantees against defects in workmanship.

## WRENCHES

Wright wrenches feel as good as they look have a reserve of strength for tough jobs. They feature the patented Wright Drive® and WrightGrip™, which provides more torque with less fastener damage.

- Satin and full polish Sets
- Adjustable Wrenches
- Striking Wrenches
- Size Ranges: 5/32" to 4" SAE and 4mm to 80mm Metric

## TORQUE PRODUCTS

Designed for precision tightening in crucial applications, Wright torque wrenches are available in three styles: micro adjustable, dial and electric dial. Other torque products include torque screwdrivers, torque multipliers and a torque tester.

- Accuracy of  $\pm 4\%$  in the clockwise direction
- Calibration traceable to NIST
- Scale in English and metric
- Drive ranges: 1/4" to 1"

## SOCKETS, RATCHETS AND ATTACHMENTS

All Wright sockets feature the patented Wright Drive® for more torque and less fastener damage. We offer single-pawl and double-pawl ratchets, as well as attachments ranging from extensions and spinners to universals and flex handles.

- SAE and Metric, 6-point and 12-point Wright Drive®
- Hex Bit Sockets
- Sets
- Handles and Attachments
- 1/4" Drive through 3-1/2" Drive

## IMPACT SOCKETS

Our impact sockets are built stronger and tougher to withstand repeated loads from impact guns. They also feature a black finish to prevent chipping.

- Wright Drive®
- SAE and Metric
- Impact Attachments
- Drive Ranges: 3/8" to 3-1/2"
- Size Ranges: 5/16" to 10-1/4" SAE and 6mm to 225mm metric

## SOCKETS, RATCHETS & ATTACHMENTS

WRIGHT SOCKETS FEATURE THE PATENTED

WRIGHT DRIVE<sup>®</sup>, WHICH PROVIDES MORE  
TORQUE WITH LESS FASTENER DAMAGE.

WRIGHT'S WIDE RANGE OF RATCHETS  
MEET YOUR EVERY NEED: DOUBLE-PAWL

RATCHETS IN 3/8" AND 1/2" DRIVES  
PROVIDE RUGGEDNESS, EXTRA STRENGTH,  
DURABILITY AND FINE TOOTH ACTION.

WE ALSO HAVE THE HANDLES AND  
ATTACHMENTS YOU'RE LOOKING FOR-

FROM EXTENSIONS AND SPINNERS TO  
UNIVERSALS AND FLEX HANDLES.



SOCKETS, RATCHETS  
& ATTACHMENTS

# 1/4" DRIVE SOCKET SETS, RATCHETS & ATTACHMENTS



200

PART NUMBER	DESCRIPTION	UOM	# OF PC'S	SIZES INCLUDED	FINISH
200	1/4" Dr., 10 Pc. 6 Pt.	SAE	10 Pieces	5/32"-1/2"	Chrome
209	1/4" Dr., 10 Pc., 12 Pt.	SAE	10 Pieces	3/16"-9/16"	Chrome
256	1/4" Dr., 11Pc. 6 Pt.	Metric	11 Pieces	4mm - 14mm	Chrome
257	1/4" Dr., 9 Pc. 6 Pt.	Metric	9 Pieces	5mm - 13mm	Chrome



2426

PART #	DESCRIPTION
2426	Ratchet—45 Teeth, 4-3/4"—Single Pawl, Swing Arc 3/4"
2492	Heavy-duty Ratchet—45 Teeth, 5-1/4", Contour Handle [Head Diameter only 1-5/64". Swing Arc 1"]



2492



2435

PART #	DESCRIPTION
2435	Flex Handle—5"



2404

PART #	DESCRIPTION
2404	4" Extension
2406	6" Extension
2410	10" Extension
2414	14" Extension
2475	Universal 1-5/16" long



2475



PART #	DESCRIPTION	LENGTH
2453	1/4" F x 3/8" M	1"



# 3/8" DRIVE SOCKET SETS



300

PART NUMBER	DESCRIPTION	UOM	NUMBER OF PC'S	SIZES INCLUDED	FINISH
300	3/8" Dr. 9 Pc. 12 Pt. Deep Socket Set	SAE	9 Pieces	3/8" - 7/8"	Chrome
304	3/8" Dr., 9 Pc. 6 Pt. Deep Socket Set	SAE	9 Pieces	3/8" - 7/8"	Chrome
312	3/8" Dr., 11 Pc. 6 Pt. Std. Socket Set	SAE	11 Pieces	1/4" - 7/8"	Chrome
349	3/8" Dr., 12 PC. 12 Pt Metric Std. Socket Set	Metric	12 Pieces	8mm - 19mm	Chrome
354	3/8" Dr., 14 Pc. Metric Socket Set	Metric	14 Pieces	6mm - 19mm	Chrome
355	3/8" Dr., 14 Pc. Deep Metric Socket Set	Metric	14 Pieces	6mm - 19mm	Chrome
378	3/8" Dr., 10 Pc. 12 Pt. Std. Socket Set	SAE	10 Pieces	5/16" - 7/8"	Chrome



313

PART #	DESCRIPTION	UOM	# OF PC'S	SIZES INCLUDED	STYLE	FINISH
313	3/8" Dr., 8 Pc. Impact Socket Set	SAE	8 Pieces	5/16" - 3/4"	Standard	Black Oxide
314	3/8" Dr., 8 Pc. Deep Impact Socket Set	SAE	8 Pieces	5/16" - 3/4"	Deep	Black Oxide
356	3/8" Dr., 12 Pc. Impact Metric Socket Set 6 Pt. Std.	Metric	12 Pieces	8mm - 19mm	Standard	Black Oxide
357	3/8" Dr., 12 Pc. Impact Metric Socket Set 6 Pt. Deep	Metric	12 Pieces	8mm - 19mm	Deep	Black Oxide
358	3/8" Dr. 14 Pc. Impact Metric Socket Set 6 Pt. Deep	Metric	14 Pieces	6mm - 19mm	Deep	Black Oxide
359	3/8" Dr., 14 Pc. Impact Metric Socket Set 6 Pt. Std.	Metric	14 Pieces	6mm - 19mm	Standard	Black Oxide

# 3/8" DRIVE RATCHETS & ATTACHMENTS

# 1/2" DRIVE SOCKETS



PART #	DESCRIPTION	OVERALL LENGTH	SWING ARC	NUMBER OF HEAD TEETH	RENEWAL KIT DIAMETER	NUMBER
3425	Long Contour Handle-Double Pawl	10"	1-3/4"	41	1-1/4"	3491
3426	Knurled Grip-Double Pawl	7"	1-1/4"	41	1-1/4"	3491
3440	Compact-Palm Size Flex Head for Low Torque Application-Single Pawl	5-1/2"	1"	45	27/32"	3432
3482	Pear-Shaped Open Head Combination 3/8" and 1/4" Drives [crew chief ratchet]	7-7/8"	2-1/4"	30	1-1/8"	3483



PART #	OVERALL DESCRIPTION	LENGTH
3435	Knurled Steel Handle	8-15/32"



PART #	OVERALL DESCRIPTION
3405	6" - Extension
3408	8" - Extension
3412	12" - Extension
3475	Universal



PART #	DESCRIPTION	LENGTH
3452	3/8" F x 1/4" M	1-1/16"
3454	3/8" F x 1/2" M	1-3/8"



PART #	DESCRIPTION	LENGTH
3899	3/8" F x 1/2" M	1-3/8"



PART #	DESCRIPTION
3903	3" Impact Extension
3906	6" Impact Extension
3908	12" Impact Extension



PART #	NOM. SIZE	SHAPE	L	DS	DD	BD
<b>8 POINT SOCKET</b>						
4812	3/8"	I	1-1/2"	21/32"	15/16"	5/32"
4814	7/16"	I	1-1/2"	23/32"	15/16"	7/32"
4816	1/2"	I	1-1/2"	51/64"	15/16"	7/64"
4818	9/16"	I	1-1/2"	57/61"	-	21/64"
4820	5/8"	II	1-1/2"	1"	1"	21/64"
4822	11/16"	II	1-1/2"	1-5/64"	1-5/64"	49/64"
4824	3/4"	II	1-1/2"	1-5/32"	1-5/32"	25/32"
4826	13/16"	II	1-9/16"	1-15/64"	1-15/64"	53/64"
4828	7/8"	II	1-5/8"	1-5/16"	1-5/16"	55/64"
4830	15/16"	II	1-11/16"	1-25/64"	1-25/64"	29/32"
4832	1"	II	1-23/32"	1-15/32"	1-15/32"	59/64"
4834	1-1/16"	III	1-3/4"	1-9/16"	1-3/8"	29/32"
4836	1-1/8"	III	1-13/16"	1-41/64"	1-3/8"	15/16"
4838	1-3/16"	III	1-7/8"	1-47/64"	1-3/8"	63/64"
4840	1-1/4"	III	1-15/16"	1-53/64"	1-3/8"	1-1/32"
4842	1-5/16"	III	2"	2"	1-3/8"	1-1/32"
4844	1-3/8"	III	2-1/16"	2-1/16"	1-17/32"	1-1/8"
4846	1-7/16"	III	2-5/32"	2-5/32"	1-17/32"	1-5/32"
4848	1-1/2"	III	2-3/16"	2-15/64"	1-17/32"	1-3/16"



PART #	NOM. SIZE	SHAPE	L	DS	DD	BD
<b>12 POINT SOCKET</b>						
4864	7/16"	I	1-15/32"	47/64"	15/16"	7/32"
4866	1/2"	I	1-15/32"	13/16"	15/16"	17/64"
4868	9/16"	II	1-15/32"	15/16"	15/16"	21/64"
4870	5/8"	II	1-15/32"	1"	1"	3/8"
4872	11/16"	II	1-15/32"	1-1/16"	1-1/16"	49/64"
4874	3/4"	II	1-15/32"	1-5/32"	1-5/32"	3/4"
4876	13/16"	II	1-9/16"	1-15/64"	1-15/64"	53/64"
4878	7/8"	II	1-5/8"	1-5/16"	1-5/16"	55/64"
4880	15/16"	II	1-11/16"	1-25/64"	1-25/64"	29/32"
4882	1"	II	1-23/32"	1-7/16"	1-7/16"	59/64"
4884	1-1/16"	III	1-3/4"	1-1/2"	1-3/8"	29/32"
4886	1-1/8"	III	1-13/16"	1-5/8"	1-3/8"	15/16"
4888	1-3/16"	III	1-7/8"	1-11/16"	1-3/8"	63/64"
4890	1-1/4"	III	1-15/16"	1-3/4"	1-3/8"	1-1/32"
4892	1-5/16"	III	2"	2-1/64"	1-3/8"	1-1/16"
4894	1-3/8"	III	2-1/16"	2-1/16"	1-17/32"	1-1/8"
4896	1-7/16"	III	2-1/8"	2-5/32"	1-17/32"	1-5/32"
4898	1-1/2"	III	2-3/16"	2-15/64"	1-17/32"	1-3/16"

REFERENCE DIAGRAMS

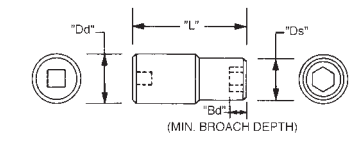

SHAPE I

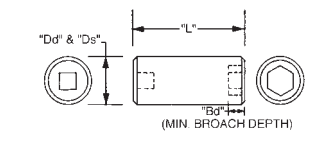

SHAPE II

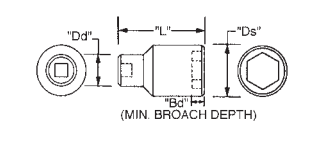

SHAPE III

# 1/2" DRIVE SOCKETS



PART #	NOM. SIZE	SHAPE	L	OS	OD	BD
<b>8 POINT SOCKET</b>						
4912	3/8"	I	3-1/4"	21/32"	15/16"	5/32"
4914	7/16"	I	3-1/4"	23/32"	15/16"	7/32"
4916	1/2"	I	3-1/4"	51/64"	15/16"	17/64"
4918	9/16"	I	3-1/4"	7/8"	15/16"	21/64"
4920	5/8"	II	3-1/4"	1"	1"	3/8"
4922	11/16"	II	3-1/4"	1-1/16"	1-1/16"	2-35/64"
4924	3/4"	II	3-1/4"	1-5/32"	1-5/32"	2-17/32"
4926	13/16"	II	3-1/4"	1-15/64"	1-15/64"	2-1/2"
4928	7/8"	II	3-1/4"	1-5/16"	1-5/16"	2-3/4"
4930	15/16"	II	3-1/4"	1-3/8"	1-3/8"	2-27/32"
4932	1"	II	3-1/2"	1-7/16"	1-7/16"	2-45/64"
4934	1-1/16"	III	3-1/2"	1-1/2"	1-3/8"	2-21/32"
4936	1-1/8"	III	3-1/2"	1-5/8"	1-3/8"	2-5/8"
4938	1-3/16"	III	3-1/2"	1-3/4"	1-3/8"	2-19/32"
4940	1-1/4"	III	3-1/2"	1-3/4"	1-3/8"	2-19/32"
4942	1-5/16"	III	3-5/8"	2-1/64"	1-3/8"	2-9/16"
4944	1-3/8"	III	3-5/8"	2-1/16"	1-17/32"	2-35/64"
4946	1-7/16"	III	3-5/8"	2-5/32"	1-17/32"	2-17/32"
4948	1-1/2"	III	3-5/8"	2-15/64"	1-17/32"	2-1/2"
<b>12 POINT SOCKET</b>						
4964	7/16"	I	3-1/4"	47/64"	15/16"	7/32"
4966	1/2"	I	3-1/4"	13/16"	15/16"	17/64"
4968	9/16"	II	3-1/4"	15/16"	15/16"	21/64"
4970	5/8"	II	3-1/4"	1"	1"	3/8"
4972	11/16"	II	3-1/4"	1-1/16"	1-1/16"	3/8"
4974	3/4"	II	3-1/4"	1-5/32"	1-5/32"	2-1/2"
4976	13/16"	II	3-1/4"	1-15/64"	1-15/64"	2-1/2"
4978	7/8"	II	3-1/4"	1-5/16"	1-5/16"	2-3/4"
4980	15/16"	II	3-1/4"	1-3/8"	1-3/8"	2-27/32"
4982	1"	II	3-1/2"	1-7/16"	1-7/16"	2-45/64"
4984	1-1/16"	III	3-1/2"	1-1/2"	1-3/8"	2-21/32"
4986	1-1/8"	III	3-1/2"	1-5/8"	1-3/8"	2-5/8"
4988	1-3/16"	III	3-1/2"	1-3/4"	1-3/8"	2-19/32"
4992	1-5/16"	III	3-5/8"	2-1/64"	1-3/8"	2-9/16"
4994	1-3/8"	III	3-5/8"	2-1/16"	1-17/32"	2-35/64"
4996	1-7/16"	III	3-5/8"	2-5/32"	1-17/32"	2-17/32"



PART #	NOM. SIZE	SHAPE	L	OS	OD	BD
4112	3/8"	I	1-1/2"	39/64"	7/8"	5/32"
4114	7/16"	I	1-1/2"	43/64"	7/8"	7/32"
4116	1/2"	I	1-1/2"	47/64"	7/8"	17/64"
4118	9/16"	I	1-1/2"	13/16"	7/8"	21/64"
4119	19/32"	II	1-1/2"	55/64"	55/64"	23/64"
4120	5/8"	II	1-1/2"	7/8"	7/8"	3/8"
4121	21/32"	II	1-1/2"	15/16"	15/16"	3/8"
4122	11/16"	II	1-1/2"	63/64"	63/64"	49/64"
4124	3/4"	II	1-1/2"	1-1/16"	1-1/16"	3/4"
4125	25/32"	II	1-1/2"	1-7/64"	1-7/64"	49/64"
4126	13/16"	II	1-9/16"	1-1/8"	1-1/8"	13/16"
4128	7/8"	II	1-5/8"	1-3/16"	1-3/16"	55/64"
4129	29/32"	II	1-5/8"	1-7/32"	1-7/32"	27/32"
4130	15/16"	II	1-5/8"	1-9/32"	1-9/32"	27/32"
4131	31/32"	II	1-21/32"	1-19/64"	1-19/64"	55/64"
4132	1"	III	1-21/32"	1-23/64"	1-23/64"	27/32"
4134	1-1/16"	III	1-3/4"	1-7/16"	1-7/64"	29/32"
4136	1-1/8"	III	1-13/16"	1-1/2"	1-7/64"	15/16"
4138	1-3/16"	III	1-7/8"	1-19/32"	1-7/64"	63/64"
4140	1-1/4"	III	1-59/64"	1-21/32"	1-7/64"	1"
4142	1-5/16"	III	1-31/32"	1-13/16"	1-7/64"	1-1/64"
4144	1-3/8"	III	2"	1-7/8"	1-1/4"	1-3/64"
4146	1-7/16"	III	2-1/16"	1-61/64"	1-1/4"	1-3/32"
4148	1-1/2"	III	2-1/8"	2"	1-1/4"	1-1/8"



PART #	NOM. SIZE	SHAPE	L	OS	OD	BD
4612	3/8"	I	3-3/64"	39/64"	13/16"	37/64"
4614	7/16"	I	3-3/64"	11/16"	13/16"	23/32"
4616	1/2"	I	3-3/64"	47/64"	7/8"	17/64"
4618	9/16"	I	3-3/64"	13/16"	7/8"	21/64"
4620	5/8"	II	3-3/64"	7/8"	7/8"	3/8"
4622	11/16"	II	3-3/64"	63/64"	63/64"	2-1/8"
4624	3/4"	II	3-3/64"	1-1/16"	1-1/16"	2-1/8"
4626	13/16"	II	3-3/64"	1-1/8"	1-1/8"	2-1/8"
4628	7/8"	II	3-3/64"	1-3/16"	1-3/16"	2-1/8"
4630	15/16"	II	3-3/64"	1-9/32"	1-9/32"	2-1/8"
4632	1"	III	3-3/64"	1-23/64"	-	2-1/8"
4634	1-1/16"	III	3-3/64"	1-7/16"	1-7/64"	2-1/8"
4636	1-1/8"	III	3-3/64"	1-1/2"	1-7/64"	2-1/8"
4638	1-3/16"	III	3-3/64"	1-19/32"	1-7/64"	2-1/8"
4640	1-1/4"	III	3-3/64"	1-21/32"	1-7/64"	2-1/8"
4642	1-5/16"	III	3-3/64"	1-13/16"	1-7/64"	2-1/8"
4644	1-3/8"	III	3-3/64"	1-7/8"	1-1/4"	2-1/8"
4646	1-7/16"	III	3-3/64"	1-61/64"	1-1/4"	2-1/8"
4648	1-1/2"	III	3-3/64"	2-1/64"	1-1/4"	2-1/8"



# 1/2" DRIVE RATCHETS & ATTACHMENTS



	PART #	DESCRIPTION	OVERALL LENGTH	SWING ARC	NUMBER OF TEETH	HEAD DIAMETER	RENEWAL KIT NUMBER
	4425	Long Knurled Grip-Double Pawl	15"	2"	45	1-5/8"	4491
	4426	Knurled Grip-Double Pawl	10-1/4"	1-1/4"	45	1-5/8"	4491
	4428	Construction Spud Ratchet, Black, 1/2" Sq. Drive Heavy-duty Round Head-Double Pawl	15"	2"	45	1-5/8"	34491
	4480	Open Head, Pear Shape-Single Pawl	10-1/2"	3-1/4"	30	1-5/16"	4481
	4482	Pear Head, Contour Handle Scaffold Wrench, Soft Face Hammer head/special 7/8" socket-Single Pawl	10-1/2"	3-1/4"	30	1-5/16"	N/A
	4488	WrightGrip® SB Scaffold Ratchet	10-1/2"	3-1/4"	30	1-5/16"	N/A
	4494	Long Contour Grip-Double Pawl	15"	2"	45	1-5/8"	4491

	PART #	DESCRIPTION	OVERALL LENGTH
	4430	Flex Head Knurled Grip-Double Pawl	18"
	4434	Knurled Steel Handle	24"
	4435	Knurled Steel Handle	18"



PART #	OVERALL DESCRIPTION
4402	2" - Extension
4405	5" - Extension
4410	10" - Extension
4420	20" - Extension
4475	Universal



PART #	DESCRIPTION	LENGTH
4453	1/2" F x 3/8" M	1-1/2"



PART #	DESCRIPTION	LENGTH
4903	2" Pin Lock	
4905	5" Ball Lock	
4909	10" Pin Lock	
4910	24" Ball Lock (1/2" F x 3/8" M) Special Applications	
4800	Universal (Pin Lock)	2-11/16"



PART #	DESCRIPTION	LENGTH
4900	1/2" F x 3/8" M (Ball Lock)	1-1/2"
4902	1/2" F x 3/4" M (Ball Lock)	2"



# 3/4" DRIVE SOCKETS



PART #	NOM. SIZE	SHAPE	L	DS	DO	BO
6124	3/4"	I	2"	1-15/64"	1-19/64"	1/2"
6126	13/16"	II	2"	1-19/64"	1-19/64"	1/2"
6128	7/8"	II	2"	1-3/8"	1-3/8"	1/2"
6130	15/16"	II	2"	1-13/32"	1-13/32"	35/64"
6132	1"	III	2-1/32"	1-15/32"	1-15/32"	1-1/32"
6134	1-1/16"	III	2-1/16"	1-9/16"	1-29/64"	1-3/64"
6136	1-1/8"	III	2-1/8"	1-43/64"	1-29/64"	1-5/64"
6138	1-3/16"	III	2-1/8"	1-23/32"	1-29/64"	1-1/16"
6140	1-1/4"	III	2-3/16"	1-27/32"	1-37/64"	1-7/64"
6142	1-5/16"	III	2-1/4"	1-29/32"	1-37/64"	1-5/32"
6144	1-3/8"	III	2-1/4"	1-29/32"	1-37/64"	1-1/8"
6146	1-7/16"	III	2-5/16"	2-1/16"	1-37/64"	1-11/64"
6148	1-1/2"	III	2-5/16"	2-3/32"	1-39/64"	1-5/32"
6150	1-9/16"	III	2-7/16"	2-3/32"	1-39/64"	1-1/4"
6152	1-5/8"	III	2-1/2"	2-7/32"	1-39/64"	1-19/64"
6154	1-11/16"	III	2-1/2"	2-5/16"	1-5/8"	1-9/32"
6156	1-3/4"	III	2-21/32"	2-25/64"	1-43/64"	1-13/32"
6158	1-13/16"	III	2-13/16"	2-1/2"	1-3/4"	1-35/64"
6160	1-7/8"	III	2-7/8"	2-19/32"	1-3/4"	1-37/64"
6164	2"	III	3"	2-11/16"	1-3/4"	1-11/16"
6166	2-1/16"	III	3-1/32"	2-47/64"	1-61/64"	1-45/64"
6168	2-1/8"	III	3-1/16"	2-55/64"	1-61/64"	1-23/32"
6170	2-3/16"	III	3-1/16"	2-55/64"	1-61/64"	1-11/16"
6172	2-1/4"	III	3-3/16"	3-1/32"	1-61/64"	1-51/64"
6176	2-3/8"	III	3-1/4"	3-1/32"	1-61/64"	2"



PART #	NOM. SIZE	SHAPE	L	DS	DO	BO
6524	3/4"	II	3-1/2"	1-15/64"	1-19/64"	1/2"
6526	13/16"	II	3-1/2"	1-19/64"	1-19/64"	1/2"
6528	7/8"	II	3-1/2"	1-3/8"	1-3/8"	17/32"
6530	15/16"	II	3-1/2"	1-27/64"	1-27/64"	9/16"
6532	1"	II	3-1/2"	1-15/32"	1-15/32"	19/32"
6534	1-1/16"	III	3-1/2"	1-37/64"	1-7/16"	2-1/2"
6536	1-1/8"	III	3-1/2"	1-21/32"	1-7/16"	2-31/64"
6538	1-3/16"	III	3-1/2"	1-23/32"	1-32/64"	2-15/32"
6540	1-1/4"	III	3-1/2"	1-55/64"	1-1/2"	2-7/16"
6542	1-5/16"	III	3-1/2"	1-29/32"	1-9/16"	2-27/64"
6544	1-3/8"	III	3-1/2"	1-29/32"	1-9/16"	2-13/32"
6546	1-7/16"	III	3-1/2"	2-1/16"	1-43/64"	2-3/8"
6548	1-1/2"	III	3-1/2"	2-3/32"	1-43/64"	2-23/64"
6552	1-5/8"	III	3-1/2"	2-7/32"	1-39/64"	2-5/16"

# 3/4" DRIVE POWER & IMPACT SOCKETS



PART #	NOM. SIZE	RET RING	SHAPE	L	DS	DO	BO
6818	9/16"	6581	I	2-3/32"	1"	1-5/8"	21/64"
6820	5/8"	6581	I	2-3/32"	1-3/32"	1-5/8"	9/32"
6822	11/16"	6581	I	2-3/32"	1-5/32"	1-5/8"	5/16"
6824	3/4"	6581	I	2-3/32"	1-1/4"	1-5/8"	9/16"
6826	13/16"	6581	I	2-1/8"	1-3/8"	1-5/8"	39/64"
6828	7/8"	6581	I	2-1/8"	1-1/2"	1-5/8"	39/64"
6830	15/16"	6581	I	2-1/8"	1-9/16"	1-5/8"	19/32"
6832	1"	6581	II	2-1/8"	1-5/8"	1-5/8"	35/64"
6834	1-1/16"	6581	II	2-1/8"	1-11/16"	1-11/16"	1-7/64"
6836	1-1/8"	6582	II	2-1/8"	1-3/4"	1-3/4"	1-3/32"
6838	1-3/16"	6582A	II	2-1/8"	1-7/8"	1-7/8"	1-1/16"
6840	1-1/4"	6582A	II	2-1/8"	2"	2"	1-3/64"
6842	1-5/16"	6582A	II	2-1/8"	2-1/16"	2-1/16"	1-1/32"
6844	1-3/8"	6582A	III	2-1/4"	2-1/8"	1 29/32"	1-1/8"
6846	1-7/16"	6582A	III	2-1/4"	2-13/57"	1-29/32"	1-1/8"
6848	1-1/2"	6582A	III	2-1/2"	2-5/16"	1-29/32"	1-23/64"
6850	1-9/16"	6582A	III	2-1/2"	2-13/32"	1-29/32"	1-11/32"
6852	1-5/8"	6582A	III	2-1/2"	2-31/64"	1-29/32"	1-5/16"
6854	1-11/16"	6582A	III	2-5/8"	2-9/16"	1-29/32"	1-27/64"
6856	1-3/4"	6582A	III	2-5/8"	2-41/64"	1-29/32"	1-13/32"
6858	1-13/16"	6582A	III	2-5/8"	2-23/32"	1-29/32"	1-3/8"
6860	1-7/8"	6582A	III	2-3/4"	2-13/16"	1-29/32"	1-31/64"
6862	1-15/16"	6582A	III	2-3/4"	2-57/64"	1-29/32"	1-15/32"
6864	2"	6582A	III	2-7/8"	2-31/32"	1-29/32"	1-9/16"

## 8 PT. DOUBLE SQUARE IMPACT (RAILROAD) SOCKETS



PART NUMBER	NOM. SIZE	RET RING	SHAPE	L	DS	DO	BO
6865	3/4"	6581	II	2-1/8"	1-5/8"	1-5/8"	1/2"
6866	13/16"	6581	II	2-1/8"	1-11/16"	1-11/16"	1/2"
6868	7/8"	6582	II	2-1/8"	1-3/4"	1-3/4"	1-7/64"
6870	15/16"	6582	II	2-1/8"	1-13/16"	1-13/16"	1-5/64"
6872	1"	6582A	II	2-1/8"	2"	2"	1-3/64"
6874	1-1/16"	6582A	III	2-1/4"	2-1/8"	1-29/32"	1-5/32"
6876	1-1/8"	6582A	III	2-1/4"	2-1/4"	1-29/32"	1-1/8"
6878	1-3/16"	6582A	III	2-1/2"	2-5/16"	1-29/32"	1-11/32"
6880	1-1/4"	6582A	III	2-1/2"	2-7/16"	1-29/32"	1-21/32"
6882	1-5/16"	6582A	III	2-5/8"	2-1/2"	1-29/32"	1-27/64"
6886	1-7/16"	6582A	III	2-3/4"	2-11/32"	1-29/32"	1-1/2"

Meets or exceeds ASME B107.110. Refer to reference diagrams on page 234.



# 3/4" DRIVE RATCHETS, HANDLES & ATTACHMENTS

## RATCHETS

Drop forged, one-piece handle. Handle design allows operator to "feel" the fastener. Precision machined 45 tooth head gives long life and short arc swing. Kit is easily removed for cleaning or replacement.

PART NUMBER	DESCRIPTION	OVERALL LENGTH
6400	Knurled Steel Handle	24"
36400	Black Knurled Steel Handle	24"
6425	Long Black Knurled Steel Handle	42"

Meets or exceeds ASME B107.110.

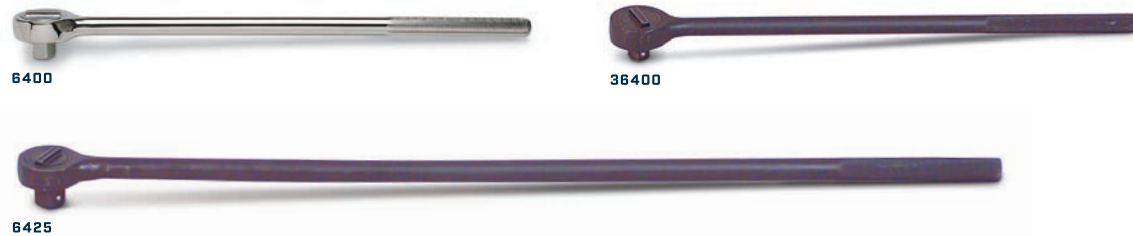

Sturdy Single Pawl

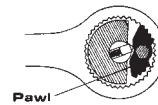

## RENEWAL KIT

PART NUMBER	DESCRIPTION
6402	45 Tooth, 6400 Ratchet
36402	For 6425, 36400 Ratchet—Black

Note: When cleaning your ratchet re-lubricate with light oil only.



## FLEX HANDLES

Steel pin and tension washer construction for added strength. No binding or locked joint.

PART NUMBER	DESCRIPTION	OVERALL LENGTH
6435	Knurled Steel Handle	23"
36435	Black Knurled Steel Handle	23"

Meets or exceeds ASME B107.110.

## IMPACT EXTENSIONS



PART NUMBER	DESCRIPTION	RET RING
69E24	24"	6581
69E36	36"	6581

Meets or exceeds ASME B107.110.

# 1" DRIVE RATCHETS, HANDLES & ATTACHMENTS



## RATCHETS

Drop forged, one-piece handle. Handle design allows operator to "feel" the fastener. Precision-machined 45 tooth head gives long life and short arc swing. Kit is easily removed for cleaning or replacement.

PART NUMBER	DESCRIPTION	OVERALL LENGTH
8400	Knurled Steel Handle	30"
38400	Black Knurled Steel Handle	30"
8425	Long Black Knurled Steel Handle	42"

Meets or exceeds ASME B107.110.

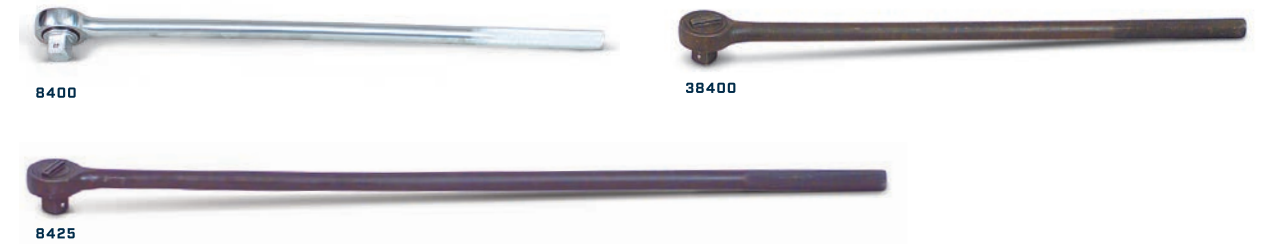

Sturdy Single Pawl

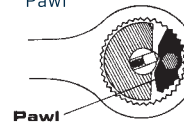

## RENEWAL KIT

PART NUMBER	DESCRIPTION
8402	45 Tooth, 8400 Ratchet
38402	For 8425, 38400 Ratchet - Black

Meets or exceeds ASME B107.110.

# 3/4" DRIVE SOCKETS, RATCHETS & ATTACHMENTS



PART #	NOM. SIZE	RET RING	SHAPE	L	DS	DD	BD
6918	9/16"	6581	I	3-7/64"	1"	1-5/8"	21/64"
6920	5/8"	6581	I	3-7/64"	1-7/64"	1-5/8"	3/8"
6922	11/16"	6581	I	3-7/64"	1-11/64"	1-5/8"	3/8"
6924	3/4"	6581	I	3-7/64"	1-1/4"	1-5/8"	9/16"
6926	13/16"	6581	I	3-7/64"	1-3/8"	1-5/8"	39/64"
6928	7/8"	6581	I	3-7/64"	1-1/2"	1-5/8"	39/64"
6930	15/16"	6581	I	3-7/64"	1-9/16"	1-5/8"	19/32"
6932	1"	6581	II	3-7/64"	1-5/8"	1-5/8"	35/64"
6934	1-1/16"	6582	II	3-1/2"	1-11/16"	1-11/16"	2-31/64"
6936	1-1/8"	6582A	II	3-1/2"	1-3/4"	1-3/4"	2-15/32"
6938	1-3/16"	6582A	II	3-1/2"	1-27/32"	1-27/32"	2-7/16"
6940	1-1/4"	6582A	II	3-1/2"	1-59/64"	1-59/64"	2-27/64"
6942	1-5/16"	6582A	II	3-1/2"	2"	2"	2-1/2"
6944	1-3/8"	6582A	II	3-1/2"	2-1/16"	1-29/32"	2-13/32"
6946	1-7/16"	6582A	III	3-1/2"	2-5/32"	1-29/32"	2-3/8"
6948	1-1/2"	6582A	III	3-1/2"	2-15/64"	1-29/32"	2-23/64"
6950	1-9/16"	6582A	III	3-1/2"	2-5/16"	1-29/32"	2-11/32"
6952	1-5/8"	6582A	III	3-1/2"	2-13/32"	1-29/32"	2-5/16"
6954	1-11/16"	6582A	III	3-1/2"	2-31/64"	1-29/32"	2-19/64"
6956	1-3/4"	6582A	III	3-1/2"	2-9/16"	1-29/32"	2-9/32"
6958	1-13/16"	6582A	III	3-1/2"	2-41/64"	1-29/32"	2-1/4"
6960	1-7/8"	6582A	III	3-1/2"	2-23/32"	1-29/32"	2-15/64"
6962	1-15/16"	6582A	III	3-1/2"	2-13/16"	1-29/32"	2-7/32"
6964	2"	6582A	III	3-1/2"	2-57/64"	1-29/32"	2-25/64"
6966	2-1/16"	6582A	III	3-1/2"	2-31/32"	1-29/32"	2-7/16"
6968	2-1/8"	6582A	III	3-1/2"	3-3/64"	1-29/32"	2-7/16"



PART #	DESCRIPTION	OVERALL LENGTH
6400	Ratchet 3/4" DR	24"
6425	Ratchet RR Track 3/4" DR	42"



PART #	DESCRIPTION	OVERALL LENGTH
6435	Knurled Steel Handle	23"



PART #	DESCRIPTION
6403	3-1/2" - Extension
6408	8" - Extension
6416	16" - Extension
6475	3-13/16" Universal



PART NUMBER	DESCRIPTION	LENGTH
6450	3/4" F x 1/2" M	2-1/8"



PART #	DESCRIPTION	RET RING	OVERALL LENGTH	OD
6907	7" - Impact Extensions (with Pin Hole)	6581		
6910	10" - Impact Extensions (with Pin Hole)	6581		
6913	13" - Impact Extensions (with Pin Hole)	6581		
6800	Universal	6581	3-1/2"	1-7/8"



PART #	DESCRIPTION	RET RING	LENGTH
6900	3/4" F x 1/2" M	6580	2-1/8"
6901	3/4" F x 1" M	6581	2-1/2"

## "O" RINGS AND PINS AS AN ALTERNATIVE TO RET RINGS

RET RING	RET RING ID	"O" RING	"O" RING WIDTH	"O" RING ID	PIN	PIN OD	PIN LENGTH
-	-	6574	1/8"	1-1/8"	6573	3/16"	1-1/16"
6580	1-1/4"	6575	1/8"	1-1/4"	6576	3/16"	1-1/4"
6581	1-7/16"	6577	1/8"	1-7/16"	6576	3/16"	1-1/4"

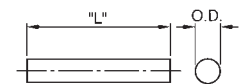
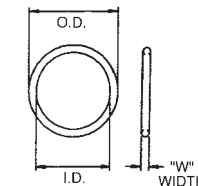

# 1" DRIVE SOCKETS



PART #	NOM. SIZE	SHAPE	L	OS	OD	BD
8134	1-1/16"	II	2-9/32"	1-41/64"	1-41/64"	5/8"
8136	1-1/8"	II	2-9/32"	1-11/16"	1-11/16"	21/32"
8138	1-3/16"	II	2-9/32"	1-49/64"	1-49/64"	21/32"
8140	1-1/4"	II	2-9/32"	1-53/64"	1-53/64"	3/4"
8142	1-5/16"	II	2-11/32"	1-57/64"	1-57/64"	49/64"
8144	1-3/8"	III	2-7/16"	1-61/64"	1-3/4"	25/32"
8146	1-7/16"	III	2-1/2"	2"	1-3/4"	7/8"
8148	1-1/2"	III	2-9/16"	2-9/64"	1-3/4"	55/64"
8150	1-9/16"	III	2-5/8"	2-13/64"	1-3/4"	1"
8152	1-5/8"	III	2-11/16"	2-1/4"	1-3/4"	1"
8154	1-11/16"	III	2-3/4"	2-25/64"	1-15/16"	1"
8156	1-3/4"	III	2-13/16"	2-33/64"	1-15/16"	1-3/32"
8158	1-13/16"	III	2-7/8"	2-37/64"	1-15/16"	1-1/8"
8160	1-7/8"	III	2-15/16"	2-41/64"	2-1/4"	1-1/8"
8162	1-15/16"	III	3"	2-3/4"	2-1/4"	1-7/32"
8164	2"	III	3"	2-3/4"	2-1/4"	1-7/32"
8166	2-1/16"	III	3-1/16"	2-61/64"	2-1/4"	1-7/32"
8168	2-1/8"	III	3-1/16"	2-61/64"	2-1/4"	1-3/8"
8170	2-3/16"	III	3-9/32"	3"	2-1/4"	1-3/8"
8172	2-1/4"	III	3-9/32"	3-5/64"	2-1/4"	1-3/8"
8174	2-5/16"	III	3-9/32"	3-11/64"	2-1/4"	1-3/8"
8176	2-3/8"	III	3-5/16"	3-1/4"	2-1/4"	1-3/8"
8178	2-7/16"	III	3-3/8"	3-5/16"	2-1/4"	1-3/8"
8180	2-1/2"	III	3-7/16"	3-3/8"	2-1/4"	1-3/8"
8182	2-9/16"	III	3-1/2"	3-3/8"	2-1/4"	1-1/2"
8184	2-5/8"	III	3-9/16"	3-9/16"	2-1/4"	1-3/4"
8188	2-3/4"	III	3-13/16"	3-23/32"	2-43/64"	1-3/4"
8190	2-13/16"	III	3-13/16"	3-27/32"	2-43/64"	1-3/4"
8194	2-15/16"	III	3-7/8"	3-31/32"	2-43/64"	2"
8196	3"	III	4-3/16"	4-1/32"	2-43/64"	2"
8197	3-1/8"	III	4-3/16"	4-3/16"	2-43/64"	2-13/64"
8198	3-3/8"	III	4-1/2"	4-35/64"	2-43/64"	2-13/64"
8199	3-1/2"	III	4-1/2"	4-35/64"	2-43/64"	2-13/64"



PART #	NOM. SIZE	RET RING	SHAPE	L	OS	OD	BD
8924	3/4"	6583	I	4"	1-7/16"	2"	7/16"
8926	13/16"	6583	I	4"	1-7/16"	2"	29/64"
8928	7/8"	6583	I	4"	1-17/32"	2"	1/2"
8930	15/16"	6583	I	4"	1-9/16"	2"	1/2"
8932	1"	6583	I	4"	1-21/32"	2"	35/64"
8933	1-1/16"	6583	I	4"	1-3/4"	2"	5/8"
8936	1-1/8"	6583	I	4"	1-13/16"	2"	21/32"
8938	1-3/16"	6583	I	4"	1-31/32"	2-1/16"	21/32"
8939	1-1/4"	6583	II	4"	2-1/16"	2-1/16"	3/4"
8942	1-5/16"	6583	II	4"	2-1/16"	2-1/16"	49/64"
8944	1-3/8"	6581A	III	4"	2-5/32"	2-1/8"	25/32"
8946	1-7/16"	6581A	III	4"	2-1/4"	2-1/8"	7/8"
8948	1-1/2"	6581A	III	4"	2-1/4"	12-1/8"	55/64"
8950	1-9/16"	6584	III	4"	2-1/2"	2-1/4"	55/64"
8952	1-5/8"	6584	III	4"	2-1/2"	2-1/4"	1"
8954	1-11/16"	6584	III	4"	2-1/2"	2-1/4"	1"
8956	1-3/4"	6585	III	4-1/16"	2-3/4"	2-7/16"	1-3/32"
8958	1-13/16"	6585	III	4-1/8"	2-3/4"	2-7/16"	1-1/8"
8960	1-7/8"	6585	III	4-3/16"	2-3/4"	2-7/16"	1-1/8"
8962	1-15/16"	6585	III	4-1/4"	2-63/64"	2-7/16"	1-1/8"
8964	2"	6585	III	4-5/16"	2-63/64"	2-7/16"	1-7/32"
8966	2-1/16"	6585	III	4-3/8"	2-63/64"	2-7/16"	1-7/32"
8968	2-1/8"	6585	III	4-7/16"	3-5/32"	2-7/16"	1-7/32"
8970	2-3/16"	6585	III	4-1/2"	3-1/4"	2-7/16"	1-3/8"
8972	2-1/4"	6585	III	4-21/32"	3-1/4"	2-7/16"	1-3/8"
8974	2-5/16"	6585	III	4-23/32"	3-13/32"	2-7/16"	1-3/8"
8976	2-3/8"	6585	III	4-3/4"	3-1/2"	2-7/16"	1-3/8"
8978	2-7/16"	6585	III	4-3/4"	3-17/32"	2-27/64"	1-3/8"
8980	2-1/2"	6585	III	4-7/8"	3-19/32"	2-7/16"	1-3/8"
8981	2-9/16"	6586	III	4-7/8"	3-23/32"	2-3/4"	1-3/8"
8984	2-5/8"	6586	III	4-7/8"	3-3/4"	2-3/4"	1-1/2"
8988	2-3/4"	6586	III	5"	3-53/64"	2-3/4"	1-3/4"
8990	2-13/16"	6586	III	5"	4"	2-3/4"	1-3/4"
8992	2-7/8"	6586	III	5"	4"	2-3/4"	1-3/4"
8994	2-15/16"	6586	III	5"	4"	2-3/4"	1-3/4"
8996	3"	6586	III	5"	4-3/16"	2-3/4"	2"
89100	3-1/8"	6586	III	5-1/2"	4-3/16"	2-3/4"	1-15/16"
89104	3-1/4"	6586	III	5-5/8"	4-17/32"	2-3/4"	2"
89108	3-3/8"	6586	III	5-3/4"	4-17/32"	2-3/4"	2"
89112	3-1/2"	6586	III	6"	4-3/4"	2-3/4"	2-13/64"
89116	3-5/8"	6587	III	6-1/8"	4-55/64"	3-1/4"	2-1/2"
89120	3-3/4"	6587	III	6-1/4"	5"	3-1/4"	2-1/2"
89124	3-7/8"	6587	III	6-3/8"	5-7/64"	3-1/4"	2-1/2"
89128	4"	6587	III	6-1/2"	5-1/4"	3-1/4"	2-1/2"
89132	4-1/8"	6587	III	6-3/4"	5-3/8"	3-1/4"	2-19/32"
89136	4-1/4"	6587	III	7"	5-17/32"	3-1/4"	2-3/4"
89144	4-1/2"	6587	III	7-1/4"	5-13/16"	3-1/4"	2-27/32"



# 1" DRIVE SOCKETS



PART NUMBER	NOM. SIZE	RET RING	SHAPE	L	DS	DD	BD
8824	3/4"	6583	I	2-1/4"	1-7/16"	2"	7/16"
8826	13/16"	6583	I	2-1/4"	1-7/16"	2"	29/64"
8828	7/8"	6583	I	2-13/32"	1-17/32"	2"	1/2"
8830	15/16"	6583	I	2-7/16"	1-9/16"	2"	1/2"
8832	1"	6583	I	2-17/32"	1-21/32"	2"	35/64"
8834	1-1/16"	6583	I	2-9/16"	1-3/4"	2"	5/8"
8836	1-1/8"	6583	I	2-9/16"	1-13/16"	2"	21/32"
8838	1-3/16"	6583	I	2-11/16"	1-31/32"	2-1/16"	21/32"
8840	1-1/4"	6583	II	2-11/16"	2-1/16"	2-1/16"	3/4"
8842	1-5/16"	6583	II	2-11/16"	2-3/32"	2-3/32"	49/64"
8844	1-3/8"	6581A	III	2-11/16"	2-5/32"	2-7/64"	25/32"
8846	1-7/16"	6581A	III	2-11/16"	2-15/64"	2-7/64"	7/8"
8848	1-1/2"	6581A	III	2-11/16"	2-23/64"	2-7/64"	55/64"
8850	1-9/16"	6584	III	2-11/16"	2-31/64"	2-15/64"	55/64"
8852	1-5/8"	6584	III	2-11/16"	2-9/16"	2-15/64"	1"
8854	1-11/16"	6584	III	2-11/16"	2-39/64"	2-15/64"	1"
8856	1-3/4"	6585	III	2-11/16"	2-47/64"	2-27/64"	1-3/32"
8858	1-13/16"	6585	III	2-11/16"	2-25/32"	2-27/64"	1-1/8"
8860	1-7/8"	6585	III	2-13/16"	2-13/16"	2-27/64"	1-1/8"
8862	1-15/16"	6585	III	3"	2-29/32"	2-27/64"	1-1/8"
8864	2"	6585	III	3"	2-31/32"	2-27/64"	1-7/32"
8866	2-1/16"	6585	III	3"	3-1/16"	2-27/64"	1-7/32"
8868	2-1/8"	6585	III	3"	3-1/8"	2-27/64"	1-7/32"
8870	2-3/16"	6585	III	3-3/16"	3-15/64"	2-27/64"	1-3/8"
8872	2-1/4"	6585	III	3-3/16"	3-19/64"	2-27/64"	1-3/8"
8874	2-5/16"	6585	III	3-3/16"	3-25/64"	2-27/64"	1-3/8"
8876	2-3/8"	6585	III	3-1/4"	3-31/64"	2-27/64"	1-3/8"
8878	2-7/16"	6585	III	3-9/32"	3-17/32"	2-27/64"	1-3/8"
8880	2-1/2"	6585	III	3-5/16"	3-37/64"	2-27/64"	1-3/8"
8882	2-9/16"	6586	III	3-5/16"	3-23/32"	2-47/64"	1-3/8"
8884	2-5/8"	6586	III	3-15/32"	3-3/4"	2-47/64"	1-1/2"
8886	2-11/16"	6586	III	3-15/32"	3-53/64"	2-47/64"	1-1/2"
8888	2-3/4"	6586	III	3-9/16"	3-29/32"	2-47/64"	1-3/4"
8890	2-13/16"	6586	III	3-11/16"	4"	2-47/64"	1-3/4"
8892	2-7/8"	6586	III	3-3/4"	4-1/16"	2-47/64"	1-3/4"
8894	2-15/16"	6586	III	3-3/4"	4-1/8"	2-47/64"	1-3/4"
8896	3"	6586	III	3-7/8"	4-15/64"	2-47/64"	2"
8897	3-1/8"	6586	III	3-15/16"	4-11/32"	2-47/64"	1-15/16"
8898	3-3/8"	6586	III	4-3/16"	3-1/4"	3-1/4"	2"
8899	3-1/2"	6586	III	4-5/16"	3-1/4"	3-1/4"	2-13/64"
88116	3-5/8"	6587	III	4-3/4"	4-7/8"	3-1/4"	2-1/2"
88120	3-3/4"	6587	III	5"	4-63/64"	3-1/4"	2-1/2"
88124	3-7/8"	6587	III	5-1/4"	5-7/64"	3-1/4"	2-1/2"
88128	4"	6587	III	5-3/8"	5-1/4"	3-1/4"	2-1/2"
88132	4-1/8"	6587	III	5-3/8"	5-25/64"	3-1/4"	2-19/32"
88136	4-1/4"	6587	III	5-1/2"	5-17/32"	3-1/4"	2-3/4"
88144	4-1/2"	6587	III	5-5/8"	5-13/16"	3-1/4"	2-27/32"

# 1" DRIVE RATCHETS & ATTACHMENTS



PART #	DESCRIPTION	OVERALL LENGTH
8400	Ratchet 1" DR	30"
8425	Ratchet RR Track 1" DR	42"



PART #	DESCRIPTION
8435	26" - Flex Handle



PART #	DESCRIPTION
8408	8" - Extension
8417	17" - Extension



PART #	DESCRIPTION	RET RING	OVERALL LENGTH	DD
8907	7" - Impact Extension	6581A		
8910	10" - Impact Extension	6581A		
8913	13" - Impact Extension	6581A		
89E24	24" - Impact Extension with Lock	6581A		
8800	Universal	6581A	4-1/2"	2-1/2"



PART #	DESCRIPTION	RET RING	LENGTH
8900	1" F x 3/4" M	6583	2-3/4"
8902	1" F x 1-1/2" M	6584	3-1/2"

## "O" RINGS AND PINS AS AN ALTERNATIVE TO RET RINGS

RET RING	RET RING ID	"O" RING	"O" RING WIDTH	"O" RING ID	PIN	PIN OD	PIN LENGTH
6583	1-3/4"	8577	1/8"	1-3/4"	8576	3/16"	1-3/4"
6584	2-1/8"	8578	1/8"	2-1/8"	8580	3/16"	2-1/8"
6585	2-1/4"	8578	1/8"	2-1/8"	8580	3/16"	2-1/8"
6586	2-1/2"	8578	1/8"	2-1/8"	8580	3/16"	2-1/8"



# 1" DRIVE IMPACT SOCKETS



## 8 PT. DOUBLE SQUARE IMPACT (RAILROAD) SOCKETS



PART NUMBER	NOM. SIZE	RET RING	SHAPE	L	DS	DD	BD
8807	7/8"	6583	I	2-9/16"	1-3/4"	2"	1/2"
8808	1"	6583	II	2-11/16"	2-1/16"	2-1/16"	35/64"
8809	1-1/8"	6583	III	2-11/16"	2-1/4"	2-1/16"	21/32"
8810	1-3/16"	6583	III	2-11/16"	2-1/4"	2-1/16"	21/32"
8810A	1-5/16"	6583	III	2-11/16"	2-1/2"	2-1/16"	49/64"
8811	1-3/8"	6583	III	2-11/16"	2-1/2"	2-1/16"	25/32"
8811A	1-7/16"	6584	III	2-11/16"	2-3/4"	2-5/16"	7/8"
8812	1-1/2"	6584	III	2-11/16"	2-3/4"	2-5/16"	55/64"
8813	1-5/8"	6584	III	3-1/2"	3-1/16"	2-5/16"	1"
8815	1-13/16"	6585	III	3-1/2"	3-1/4"	2-7/16"	1-1/8"
8816A	2"	6585	III	3-1/2"	3-1/2"	2-7/16"	1-7/32"
8817	2-3/16"	6586	III	3-1/2"	3-3/4"	2-3/4"	1-3/8"

Meets or exceeds ASME B107.110.



## 8 PT. DOUBLE SQUARE DEEP IMPACT (RAILROAD) SOCKETS



PART NUMBER	NOM. SIZE	RET RING	SHAPE	L	DS	DD	BD
8924R	3/4"	6583	I	4"	1-21/32"	2"	7/16"
8928R	7/8"	6583	I	4"	1-13/16"	2"	1/2"
8934R	1-1/16"	6583	II	4"	2-1/16"	2-1/16"	5/8"
8936R	1-1/8"	6581A	III	4"	2-1/4"	2-1/8"	21/32"
8938R	1-3/16"	6581A	III	4"	2-1/4"	2-1/8"	21/32"
8942R	1-5/16"	6584	III	4"	2-1/2"	2-1/4"	49/64"
8946R	1-7/16"	6585	III	4"	2-3/4"	2-7/16"	7/8"
8952R	1-5/8"	6585	III	4"	2-63/64"	2-7/16"	1"
8970R	2-3/16"	6586	III	4-1/2"	3-53/64"	2-3/4"	1-3/8"

Meets or exceeds ASME B107.110.

## WRENCHES

WRIGHT WRENCHES FEEL AS GOOD AS THEY LOOK. AND THEY HAVE A RESERVE OF STRENGTH FOR TOUGH JOBS. THEY FEATURE THE PATENTED WRIGHT DRIVE AND WRIGHT GRIP, WHICH PROVIDES MORE TORQUE WITH LESS FASTENER DAMAGE, DISTRIBUTING STRESS EVENLY OVER A LARGER CONTACT AREA AND AWAY FROM THE FASTENER CORNERS. THEY'RE IDEAL FOR APPLICATIONS RANGING FROM STANDARD NUTS AND BOLTS TO AEROSPACE FASTENERS. WE ALSO OFFER STRIKING WRENCHES FOR EXTRA-HEAVY-DUTY USE.



WRENCHES



# WRENCH SETS



711

PART #	DESCRIPTION	TYPE	# OF PC'S	SIZES INCLUDED	FINISH
711	11 Pc. Combination Wrench Set 3/8" - 1" 12 Pt.	Combination Wrench Set	11 Pieces	3/8" - 1" 12 Pt.	Satin
714	14 Pc. Combination Wrench Set 3/8" - 1-1/4" 12 Pt.	Combination Wrench Set	14 Pieces	3/8" - 1-1/4" 12 Pt.	Satin
715	15 Pc. 12 Pt. Combination Wrench Set 5/16"-1- 1/4"	Combination Wrench Set	15 Pieces	5/16"-1-1/4"	Satin
726	26 Pc. 12 Pt. Comb. Wrench Set 1/4"-2"	Combination Wrench Set	26 Pieces	1/4"-2"	Satin
730	16 Pc. 12 Pt. Comb. Wrench Set 1-5/16" - 2-1/2"	Combination Wrench Set	16 Pieces	1-5/16" - 2-1/2"	Satin
732	18 Pc. Open End, Double Angle 15 & 60 Degrees Wrench Set	Double Angle Wrench Set	18 Pieces	11/32" - 1-1/2"	Chrome
738	8 Pc. Open End Wrench Set 1/4" - 1-1/4"	Double Open End Wrench Set	8 Pieces	1/4" - 1-1/4"	Chrome
739	10 Pc. Open End Wrenches 1/4" - 1-1/8"	Double Box Wrench Set	10 Pieces	1/4" - 1-1/8"	Chrome
749	7 Pc. Box Wrenches 5/16" - 1-1/8"	Double Box Wrench Set	7 Pieces	5/16" - 1-1/8"	Chrome
760	28 Pc. 12 Pt. Metric Combination Wrench Set, 6mm-50mm	Metric Wrench Set	28 Pieces	6mm-50mm	Satin
911	11 Pc Full Polish Combination Wrench Set 3/8" - 1" 12 Pt.	Combination Wrench Set	11 Pieces	3/8" - 1" 12 Pt.	Full Polish Chrome
914	14 Pc. Full Polish Combination Wrench Set 3/8" - 1-1/4" 12 Pt.	Combination Wrench Set	14 Pieces	3/8" - 1-1/4" 12 Pt.	Full Polish Chrome
915	15 Pc. Full Polish Combination Wrench Set 5/16" - 1-1/4" 12 Pt.	Combination Wrench Set	15 Pieces	5/16" - 1-1/4" 12 Pt.	Full Polish Chrome
950	11 Pc. Full Polish Metric Combination Wrench Set 7mm-19mm 12 Pt	Combination Wrench Set	11 Pieces	7mm-19mm 12 Pt	Full Polish Chrome
952	15 Pc. Full Polish Metric Combination Wrench Set, 7mm-22mm 12 Pt.	Combination Wrench Set	15 Pieces	7mm-22mm 12 Pt.	Full Polish Chrome
9429	5 Pc. Ratcheting Box Wrench Set, Offset 1/4"-7/8"	Ratcheting Box Wrench Set	5 Pieces	1/4"-7/8"	Chrome

WRENCHES

# WRENCHES



WRIGHT

## ADJUSTABLE WRENCHES

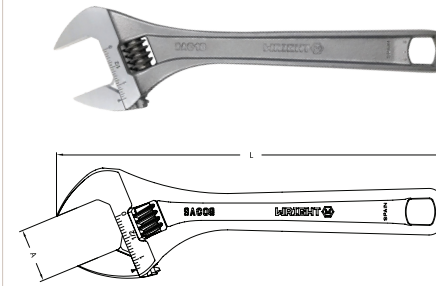

Chrome Finish

PART NUMBER	L-LENGTH	A-MAX. CAPACITY
9AC04	4"	1/2"
9AC06	6"	15/16"
9AC08	8"	1-3/16"
9AC10	10"	1-3/8"
9AC12	12"	1-1/2"
9AC15	15"	1-11/16"
9AC18	18"	2-1/8"
9AC24	24"	2-7/16"

Meets or exceeds ASME B107.100. Made in Spain.

## ADJUSTABLE WRENCHES

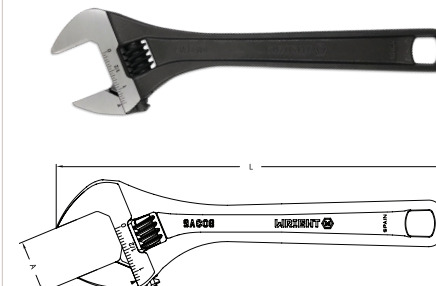

Black Industrial Finish

PART NUMBER	L-LENGTH	A-MAX. CAPACITY
9AB04	4"	1/2"
9AB06	6"	15/16"
9AB08	8"	1-3/16"
9AB10	10"	1-3/8"
9AB12	12"	1-1/2"
9AB15	15"	1-11/16"
9AB18	18"	2-1/8"
9AB24	24"	2-7/16"

Meets or exceeds ASME B107.100. Made in Spain.

## WRIGHT ULTIMATE GRIP ADJUSTABLE WRENCHES

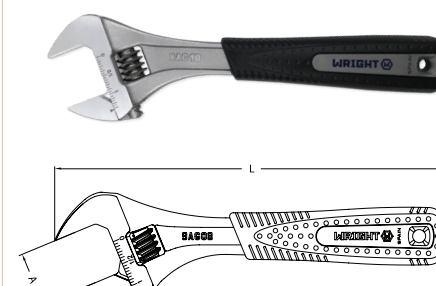

PART NUMBER	L-LENGTH	A-MAX. CAPACITY
9AG04	4"	1/2"
9AG06	6"	15/16"
9AG08	8"	1-3/16"
9AG10	10"	1-3/8"
9AG12	12"	1-1/2"

Meets or exceeds ASME B107.100. Made in Spain. \*Plastic dipped handle, not featured Wright Ultimate Grip handle

## GIANT ADJUSTABLE WRENCH—36"



PART NUMBER	L-CAPACITY	HEAD THICKNESS	WEIGHT
9AC36	2-3/4"—4-3/4" [in 1/8" increments]	1-1/8"	31 lbs.

Meets or exceeds ASME B107.100.

WRENCHES



# WRENCHES

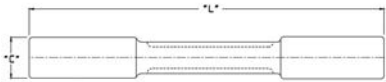
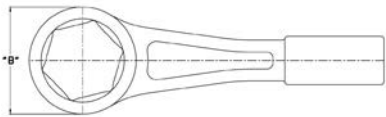

PART #	DESCRIPTION	NUT SIZE	STUD SIZE	FINISH
18H34	1-1/16" SAFETY ORANGE Straight Handle Striking Face Box Wrench	1-1/16"	5/8"	Safety Orange
18H40	1-1/4" SAFETY ORANGE Straight Handle Striking Face Box Wrench	1-1/4"	3/4"	Safety Orange
18H46	1-7/16" SAFETY ORANGE Straight Handle Striking Face Box Wrench	1-7/16"	7/8"	Safety Orange
18H52	1-5/8" SAFETY ORANGE Straight Handle Striking Face Box Wrench	1-5/8"	1"	Safety Orange
18H58	1-13/16" SAFETY ORANGE Straight Handle Striking Face Box Wrench	1-13/16"	1-1/8"	Safety Orange
18H64	2" SAFETY ORANGE Straight Handle Striking Face Box Wrench	2"	1-1/4"	Safety Orange
18H70	2-3/16" SAFETY ORANGE Straight Handle Striking Face Box Wrench	2-3/16"	1-3/8"	Safety Orange
18H76	2-3/8" SAFETY ORANGE Straight Handle Striking Face Box Wrench	2-3/8"	1-1/2"	Safety Orange
18H82	2-9/16" SAFETY ORANGE Straight Handle Striking Face Box Wrench	2-9/16"	1-5/8"	Safety Orange
18H88	2-3/4" SAFETY ORANGE Straight Handle Striking Face Box Wrench	2-3/4"	1-3/4"	Safety Orange
18H89	2-15/16" SAFETY ORANGE Straight Handle Striking Face Box Wrench	2-15/16"	1-7/8"	Safety Orange
18H90	3-1/8" SAFETY ORANGE Straight Handle Striking Face Box Wrench	3-1/8"	2"	Safety Orange
18H91	3-1/2" SAFETY ORANGE Straight Handle Striking Face Box Wrench	3-1/2"	2-1/4"	Safety Orange
18H92	3-7/8" SAFETY ORANGE Straight Handle Striking Face Box Wrench	3-7/8"	2-1/2"	Safety Orange

\*\*\*Wright Tools Fracking Wrenches are marked with the STUD and NUT sizes

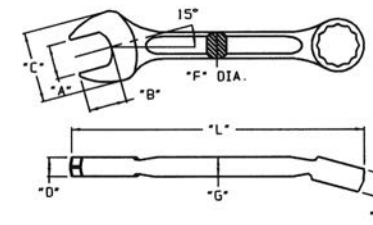

NUMBER	A	NOM. SIZE	C	B	D	WRIGHT GRIP <sup>®</sup> 12			
1142	1-5/16"	19"	2-11/16"	1-15/32"	23/32"	7/8"	1"	3/4"	
1144	1-3/8"	20"	2-11/16"	1-17/32"	23/32"	7/8"	1"	3/4"	
1146	1-7/16"	21"	3"	1-19/32"	3/4"	15/16"	1-1/16"	7/8"	
1148	1-1/2"	22"	3"	1-21/32"	3/4"	15/16"	1-1/16"	7/8"	
1150	1-9/16"	23"	3-1/2"	1-15/16"	3/4"	15/16"	1-1/8"	7/8"	
1152	1-5/8"	23"	3-1/2"	1-15/16"	3/4"	15/16"	1-1/8"	7/8"	
1154	1-11/16"	23"	3-1/2"	1-15/16"	3/4"	15/16"	1-1/8"	7/8"	
1156	1-3/4"	25-1/2"	3-3/4"	2-1/16"	13/16"	1"	1-1/4"	1"	
1158	1-13/16"	25-1/2"	3-3/4"	2-3/32"	13/16"	1"	1-1/4"	1"	
1160	1-7/8"	28"	4-1/16"	2-3/16"	7/8"	1-1/16"	1-1/4"	1"	
1164	2"	28"	4-1/16"	2-5/16"	7/8"	1-1/16"	1-1/4"	1"	
1166	2-1/16"	28-1/4"	4-1/4"	2-11/16"	59/64"	1-7/32"	1-1/4"	1"	
1168	2-1/8"	28-1/4"	4-1/4"	2-25/64"	59/64"	1-7/32"	1-1/4"	1"	
1170	2-3/16"	28-3/4"	4-1/4"	2-27/64"	59/64"	1-7/32"	1-1/4"	1"	
1172	2-1/4"	29"	4-1/4"	2-29/64"	59/64"	1-7/32"	1-1/4"	1"	
1176	2-3/8"	29-1/4"	4-1/2"	2-15/32"	1"	1-9/16"	1-3/8"	1-1/8"	
1180	2-1/2"	29-1/2"	4-1/2"	2-1/2"	1"	1-9/16"	1-3/8"	1-1/8"	
1182	2-9/16"	29-3/4"	4-1/2"	2-1/2"	1"	1-9/16"	1-3/8"	1-1/8"	
1184	2-5/8"	29-3/4"	4-3/4"	2-5/8"	1-1/32"	1-5/8"	1-3/8"	1-1/8"	
1188	2-3/4"	29-3/4"	4-3/4"	2-3/4"	1-1/32"	1-5/8"	1-3/8"	1-1/8"	

Meets or exceeds ASME B107.100

# WRENCHES



4477, 4478, 6448



8447



9S292

PART #	DESCRIPTION	TYPE	DRIVE SIZE	STYLE	TORQUE RANGE	HEAD STYLE	LENGTH
3477	Micro-Adjustable Torque Wrench, 20-100 Ft. Lbs.	Torque Wrench	3/8"	Click Type	20-100 ft. lbs.	Ratchet	15.5"
4477	Micro-Adjustable Torque Wrench, 30-150 Ft. Lbs.	Torque Wrench	1/2"	Click Type	30-150 ft. lbs.	Ratchet	19"
4478	Micro-Adjustable Torque Wrench, 50-250 Ft. Lbs.	Torque Wrench	1/2"	Click Type	50-250 ft. lbs.	Ratchet	24"
6448	Click Type 3/4" Dr. 120-600 Ft. Lbs.	Torque Wrench	3/4"	Click Type	120-600 ft. lbs.	Ratchet	41"
8447	Click Type 1" Dr. 200-1000 Ft. Lbs., Ratchet Head	Torque Wrench	1"	Click Type	200-1000 ft. lbs.	Ratchet	70"
9S292	Torque Multiplier 3/4" Sq. F - 1" Sq. M Output Capacity 2,000 Ft. Lbs.	Torque Multiplier	3/4" Sq. Female - 1" Sq. Male	Torque Multiplier	571 ft lbs: 2000 ft lbs	n/a	19-1/2"

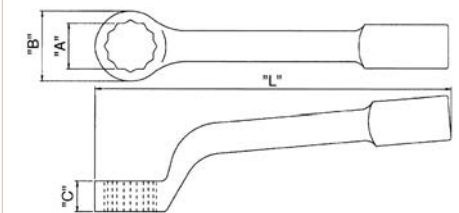

PART #	DESCRIPTION	DEGREES OFFSET	STUD SIZE	SIZE
1932	1" Offset handle Striking Face Box Wrenches, 12 Pt.	45° Offset	12 point	1"
1934	1-1/16" Offset handle Striking Face Box Wrenches, 12 Pt.	45° Offset	12 point	1-1/16"
1936	1-1/8" Offset handle Striking Face Box Wrenches, 12 Pt.	45° Offset	12 point	1-1/8"
1938	1-3/16" Offset handle Striking Face Box Wrenches, 12 Pt.	45° Offset	12 point	1-3/16"
1940	1-1/4" Offset handle Striking Face Box Wrenches, 12 Pt.	45° Offset	12 point	1-1/4"
1942	1-5/16" Offset handle Striking Face Box Wrenches, 12 Pt.	45° Offset	12 point	1-5/16"
1946	1-7/16" Offset handle Striking Face Box Wrenches, 12 Pt.	45° Offset	12 point	1-7/16"
1948	1-1/2" Offset handle Striking Face Box Wrenches, 12 Pt.	45° Offset	12 point	1-1/2"
1952	1-5/8" Offset handle Striking Face Box Wrenches, 12 Pt.	45° Offset	12 point	1-5/8"
1954	1-11/16" Offset handle Striking Face Box Wrenches, 12 Pt.	45° Offset	12 point	1-11/16"
1956	1-3/4" Offset handle Striking Face Box Wrenches, 12 Pt.	45° Offset	12 point	1-3/4"
1958	1-13/16" Offset handle Striking Face Box Wrenches, 12 Pt.	45° Offset	12 point	1-13/16"
1960	1-7/8" Offset handle Striking Face Box Wrenches, 12 Pt.	45° Offset	12 point	1-7/8"
1962	1-15/16" Offset handle Striking Face Box Wrenches, 12 Pt.	45° Offset	12 point	1-15/16"
1964	2" Offset handle Striking Face Box Wrenches, 12 Pt.	45° Offset	12 point	2"

Note: Available up to size 4-1/4"



# WRENCHES



PART #	NOM. SIZE	TUBE	LENGTH	LENGTH WITH TUBE HANDLE	A HEAD DIAMETER	B HEAD THICKNESS
19B32	1"	19A24	13"	33-1/2"	2-1/16"	7/8"
19B34	1-1/16"	19A24	13"	33-1/2"	2-1/16"	7/8"
19B36	1-1/8"	19A24	13"	33-1/2"	2-1/16"	7/8"
19B38	1-3/16"	19A24	13"	33-1/2"	2-1/16"	7/8"
19B40	1-1/4"	19A24	13"	33-1/2"	2-1/16"	7/8"
19B42	1-5/16"	19A24	13"	33-1/2"	2-1/16"	7/8"
19B44	1-3/8"	19A24	13"	33-1/2"	2-1/16"	7/8"
19B46	1-7/16"	19A24	13-1/2"	33"	2-13/16"	1-1/8"
19B48	1-1/2"	19A24	13-1/2"	33"	2-13/16"	1-1/8"
19B50	1-9/16"	19A24	13-1/2"	33"	2-13/16"	1-1/8"
19B52	1-5/8"	19A24	13-1/2"	33"	2-13/16"	1-1/8"
19B54	1-11/16"	19A36	13-1/2"	45"	2-13/16"	1-1/8"
19B56	1-3/4"	19A36	13-1/2"	45"	2-13/16"	1-1/8"
19B58	1-13/16"	19A36	13-1/2"	45"	2-13/16"	1-1/8"
19B60	1-7/8"	19A36	13-7/8"	45-1/2"	2-15/16"	1-1/8"
19B62	1-15/16"	19A36	13-7/8"	45-1/2"	2-15/16"	1-1/8"
19B64	2"	19A36	13-7/8"	45-1/2"	2-15/16"	1-1/8"

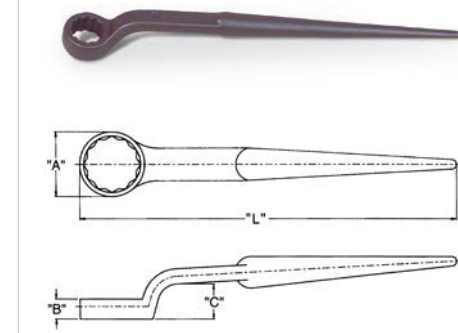

## CONSTRUCTION—STRUCTURAL I2 PT. SPUD HANDLE BOX WRENCHES



Black Industrial Finish

PART NUMBER	NOM. SIZE	A	B	C	L
1756	13/16"	1-15/32"	11/16"	1-25/32"	12"
1758	7/8"	1-15/32"	11/16"	1-25/32"	12"
1760	15/16"	1-5/8"	13/16"	1-61/64"	12"
1762	1"	1-5/8"	13/16"	1-61/64"	12"
1764	1-1/16"	1-53/64"	7/8"	2-9/64"	15"
1766	1-1/8"	1-53/64"	7/8"	2-9/64"	15"
1770	1-1/4"	2-5/64"	15/16"	2-21/64"	17"
1772	1-5/16"	2-5/64"	15/16"	2-21/64"	17"
1776	1-7/16"	2-3/8"	1-1/8"	2-3/4"	21"
1778	1-1/2"	2-3/8"	1-1/8"	2-3/4"	21"
1782	1-5/8"	2-5/8"	1-3/16"	2-7/8"	22"
1784	1-11/16"	2-5/8"	1-3/16"	2-7/8"	22"
1788	1-13/16"	2-29/32"	1-1/4"	3"	23"
1790	1-7/8"	2-29/32"	1-1/4"	3"	23"
1794	2"	3-5/32"	1-3/8"	3-5/32"	24-1/2"
1795	2-3/16"	3-15/32"	1-1/2"	3-1/2"	26"
1796	2-3/8"	3-23/32"	1-5/8"	3-11/16"	28"
1797	2-9/16"	3-29/32"	1-3/4"	3-13/16"	30"
1798	2-3/4"	4-5/32"	1-7/8"	3-29/32"	30"

Some items may be special order.

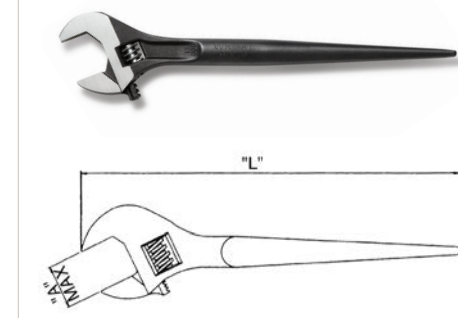

## ADJUSTABLE CONSTRUCTION SPUD WRENCHES

Black Industrial Finish

PART NUMBER	MAX OPENING	L
9413	1-1/4"	10"
9414	1-1/2"	16"

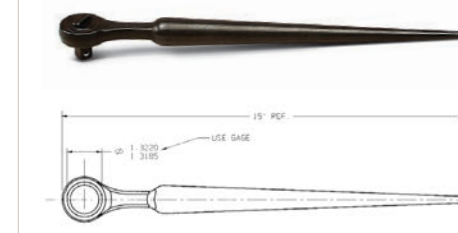

## CONSTRUCTION SPUD RATCHET

Black Industrial Finish. Features 1/2" drive and a heavy-duty round head. Requires only 4° arc swing for tight spots.

PART NUMBER	L OVERALL LENGTH	NUMBER OF TEETH	A HEAD DIAMETER	RENEWAL KIT NUMBER
4428	15"	45	1-5/8"	34491



# WRENCHES



### 8 PIECES—FULL POLISH OPEN-END SET NUMBER 738

Open-End Wrenches

PART NUMBER	DESCRIPTION
1340	1-1/8" x 1-1/4"



### 14 PIECES—15° & 60° ANGLE WRENCH SET NUMBER 733

15° & 60° Angle Wrench Set

PART NUMBER	DESCRIPTION
1383	1-1/16" x 1-1/16"
1386	1-1/4" x 1-1/4"



### DOUBLE ANGLE OPEN-END WRENCHES—15° & 60° ANGLE

15° & 60° Angle Open-End Wrenches

PART NUMBER	A NOM. SIZE	C WIDTH	D HEAD THICKNESS	L OVERALL LENGTH
1392	1-5/8" x 1-5/8"	3-3/16"	19/64"	15-7/8"
1398	2" x 2"	3-15/16"	9/16"	19-1/4"

Meets or exceeds ASME B107.100.

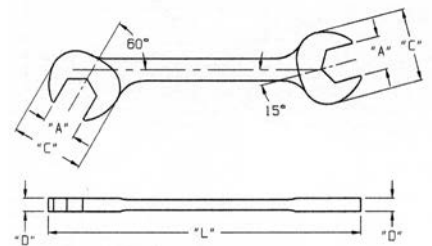

# CONSTRUCTION—STRUCTURAL WRENCHES & BULL & BARREL PINS

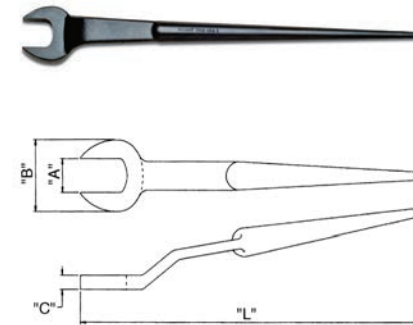

### CONSTRUCTION—STRUCTURAL SPUD WRENCHES, OFFSET HEAD

Black Industrial Finish

PART NUMBER	A NOM. SIZE	B	C	L	NUT TYPE	BOLT SIZE
1726	13/16"	2"	17/32"	14-1/2"	U.S. Regular	1/2"
1728	7/8"	2"	17/32"	14-1/2"	U.S. Heavy	1/2"
1730	15/16"	2"	17/32"	14-1/2"	Utility	5/8"
1732	1"	2"	17/32"	14-1/2"	U.S. Regular	5/8"
1734	1-1/16"	2-1/4"	5/8"	17"	U.S. Heavy	5/8"
1736	1-1/8"	2-1/4"	5/8"	17"	U.S. Regular	3/4"
1740	1-1/4"	2-13/16"	11/16"	17-1/2"	U.S. Heavy	3/4"
1742	1-5/16"	2-13/16"	11/16"	19"	U.S. Regular	7/8"
1746	1-7/16"	3-1/8"	3/4"	20"	U.S. Heavy	7/8"
1748	1-1/2"	3-1/8"	3/4"	20"	U.S. Regular	1"
1752	1-5/8"	3-19/32"	13/16"	23"	U.S. Heavy	1"



### SLUGGING WRENCH ADAPTOR

PART NUMBER	DESCRIPTION
1900	1"M x 1"F
1901	3/4"M x 3/4"F

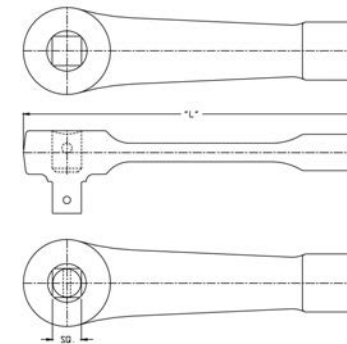

### BROAD HEAD BULL PINS

PART NUMBER	TOP DIAMETER	POINT DIAMETER	LENGTH
9A649	1-1/16"	1/4"	10-3/8"
9A650	1-1/4"	5/16"	13-3/4"



# COMBINATION WRENCHES



## COMBINATION WRENCHES—12 PT.



Black Industrial Finish

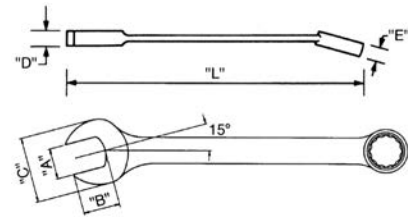

PART NUMBER	A NOM. SIZE	L	C	B	D	E
31108	1/4"	4-59/64"	35/64"	5/16"	11/64"	13/64"
31110	5/16"	5-1/2"	43/64"	3/8"	3/16"	15/64"
31112	3/8"	6"	51/64"	29/64"	7/32"	17/64"
31114	7/16"	6-1/2"	15/16"	17/32"	1/4"	19/64"
31116	1/2"	7-5/32"	1-1/16"	19/32"	17/64"	11/32"
31118	9/16"	7-15/16"	1-11/64"	11/16"	19/64"	23/64"
31120	5/8"	8-35/64"	1-19/64"	3/4"	5/16"	13/32"
31122	11/16"	9-1/8"	1-27/64"	53/64"	11/32"	7/16"
31124	3/4"	10-3/64"	1-35/64"	29/32"	23/64"	15/32"
31126	13/16"	10-53/64"	1-43/64"	63/64"	27/64"	1/2"
31128	7/8"	11-3/4"	1-51/64"	61/64"	7/16"	33/64"
31130	15/16"	12-9/16"	1-29/32"	31/32"	15/32"	17/32"
31132	1"	13-5/16"	2-1/32"	1-13/64"	15/32"	5/8"
31134	1-1/16"	14-1/4"	2-5/32"	1-19/64"	31/64"	21/32"
31136	1-1/8"	15-1/8"	2-17/64"	1-23/64"	35/64"	11/16"
31138	1-3/16"	15-15/16"	2-25/64"	1-7/16"	17/32"	23/32"
31140	1-1/4"	16-13/16"	2-1/2"	1-33/64"	19/32"	3/4"

Meets or exceeds ASME B107.100.

## COMBINATION WRENCHES—12 PT. HEAVY-DUTY FLAT STEM



Black Industrial Finish

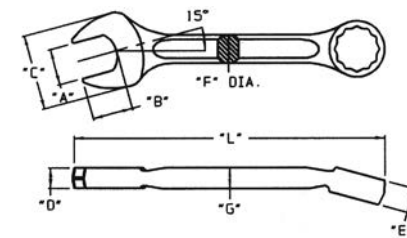

PART NUMBER	A NOM. SIZE	L	C	B	D	E	F	G
31142	1-5/16"	19"	2-11/16"	1-15/32"	23/32"	7/8"	1"	
31144	1-3/8"	20"	2-11/16"	1-17/32"	23/32"	7/8"	1"	
31146	1-7/16"	21"	3"	1-19/32"	3/4"	15/16"	1-1/16"	
31148	1-1/2"	22"	3"	1-21/32"	3/4"	15/16"	1-1/16"	
31152	1-5/8"	23"	3-1/2"	1-15/16"	3/4"	15/16"	1-1/8"	
31154	1-11/16"	23"	3-1/2"	1-15/16"	3/4"	15/16"	1-1/8"	
31156	1-3/4"	25-1/2"	3-3/4"	2-1/16"	13/16"	1"	1-1/4"	
31158	1-13/16"	25-1/2"	3-3/4"	2-3/32"	13/16"	1"	1-1/4"	
31160	1-7/8"	28"	4-1/16"	2-3/16"	7/8"	1-1/16"	1-1/4"	
31164	2"	28"	4-1/16"	2-5/16"	7/8"	1-1/16"	1-1/4"	
31166	2-1/16"	28-1/4"	4-1/4"	2-11/16"	59/64"	1-7/32"	1-1/4"	
31168	2-1/8"	28-1/2"	4-1/4"	2-25/64"	59/64"	1-7/32"	1-1/4"	
31170	2-3/16"	28-3/4"	4-1/4"	2-27/64"	59/64"	1-7/32"	1-1/4"	
31172	2-1/4"	29"	4-1/4"	2-29/64"	59/64"	1-7/32"	1-1/4"	
31176	2-3/8"	29-1/4"	4-1/2"	2-15/32"	1"	1-9/16"	1-3/8"	
31180	2-1/2"	29-1/2"	4-1/2"	2-1/2"	1"	1-9/16"	1-3/8"	
1190	2-13/16"	34"	5-3/4"	3"	1-3/8"	1-7/8"	1-1/2"	1-1/4"
1192	2-7/8"	34"	5-3/4"	3"	1-3/8"	1-7/8"	1-1/2"	1-1/4"
1194	2-15/16"	34"	5-3/4"	3"	1-3/8"	1-7/8"	1-1/2"	1-1/4"
1196	3"	34"	5-3/4"	3"	1-3/8"	1-7/8"	1-1/2"	1-1/4"
1198	3-1/16"	34"	5-3/4"	3"	1-3/8"	1-7/8"	1-1/2"	1-1/4"
11X00	3-1/8"	37"	6-3/16"	3-1/4"	1-3/8"	1-7/8"	1-3/4"	1-7/16"
11X04	3-1/4"	37"	6-3/16"	3-1/4"	1-3/8"	1-7/8"	1-3/4"	1-7/16"
11X08	3-3/8"	37"	6-3/16"	3-1/2"	1-3/8"	1-7/8"	1-3/4"	1-7/16"
11X12	3-1/2"	37"	6-3/16"	3-1/2"	1-3/8"	1-7/8"	1-3/4"	1-7/16"
11X16	3-5/8"	40"	7"	3-7/8"	1-5/8"	2"	1-7/8"	1-1/2"
11X20	3-3/4"	40"	7"	3-7/8"	1-5/8"	2"	1-7/8"	1-1/2"
11X24	3-7/8"	40"	7"	3-15/16"	1-5/8"	2"	1-7/8"	1-1/2"
11X28	4"	40"	7"	4"	1-5/8"	2"	1-7/8"	1-1/2"

Meets or exceeds ASME B107.100.





# THE WRIGHT WAY

**THERE'S ALWAYS  
THE EASY WAY,  
AND THEN  
THERE'S THE  
WRIGHT WAY.**

Since 1927, 'hard work' has been more than just a slogan and 'easy' just isn't part of our family vocabulary. Getting the job done is the truest test of any tool however, ensuring your safety is our company's purpose.

— FOR MORE INFORMATION ON  
OUR SAFETY PROGRAM, PLEASE GO  
TO [WRIGHTTOOL.COM/SAFETY](http://WRIGHTTOOL.COM/SAFETY)

THAT'S NOT  
ALL WE HAVE  
TO OFFER.  
**ASK TO SEE  
OUR FULL  
CATALOG.**

Product questions,  
call Customer Service:  
1 800 321 2902

Locate a local or  
international distributor:  
[wrighttool.com](http://wrighttool.com)

Order now via email or fax:  
[orders@wrighttool.com](mailto:orders@wrighttool.com)  
1 800 543 2095

**WE FORGE-TO-FINISH  
MORE THAN 4,000  
PROFESSIONAL-GRADE  
HAND TOOLS MADE  
AND ENGINEERED IN  
THE USA.**



ENSURING  
CONFIDENCE  
TO GET THE JOB  
DONE SAFELY  
AND ON TIME

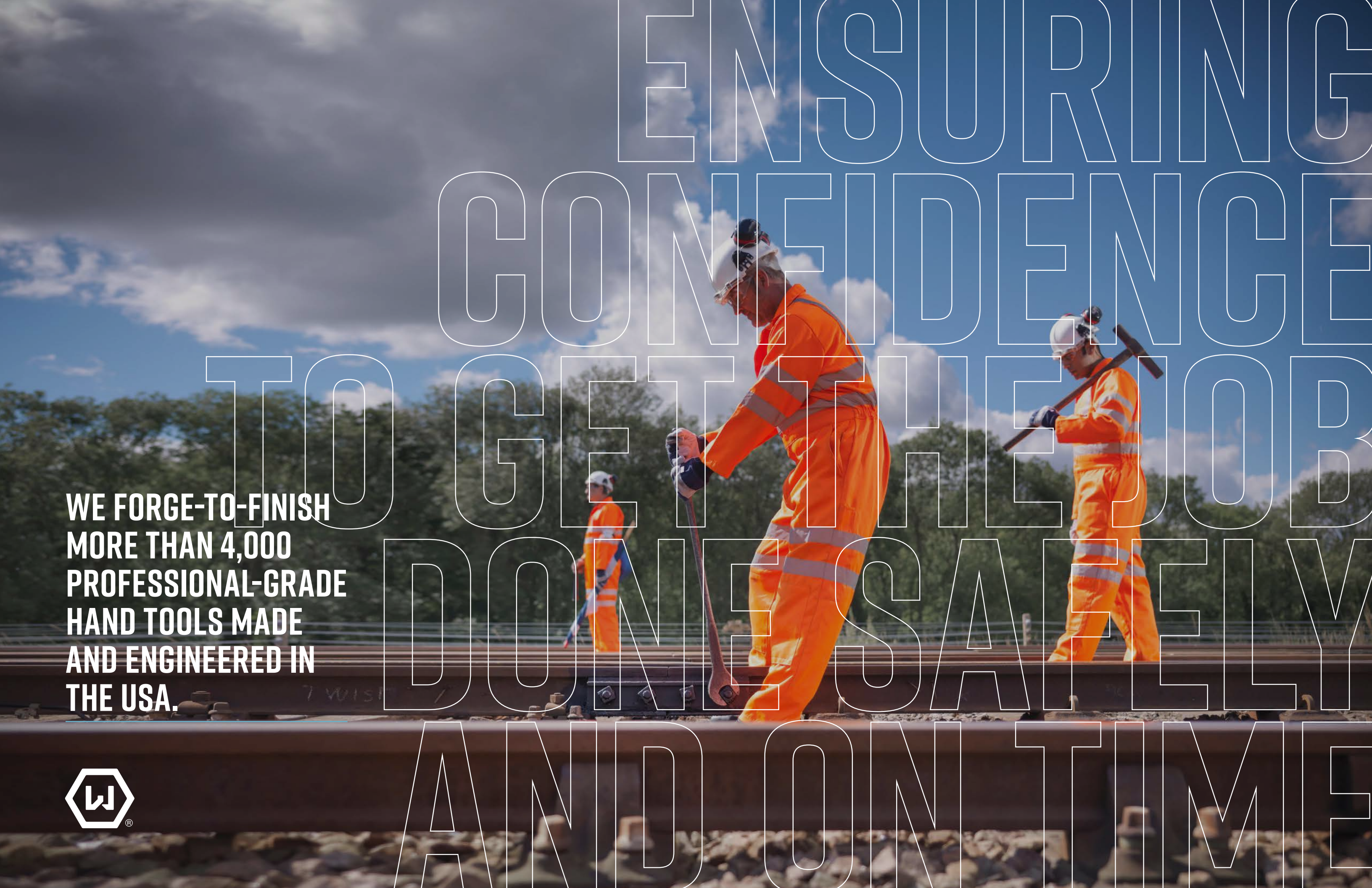





WRIGHT 



*Jim Henderson*  
President, Dynamic Sales Co., Inc.

cell **314.941.4984**  
[dynamicsalescoinc.com](http://dynamicsalescoinc.com)

*Service, Quality, Commitment and Integrity since 1966*